

# intertextile

SHANGHAI apparel fabrics

中国国际纺织面料及辅料(春夏)博览会

China International Trade Fair for Apparel Fabrics  
and Accessories – Spring Edition

2026.3.11 – 13

国家会展中心 (上海)

National Exhibition and Convention  
Center (Shanghai), China

## 同期活动

### Fringe Programme



研讨会日程  
Seminar schedule



messe frankfurt

## 同期活动场地 Fringe Programme Venues

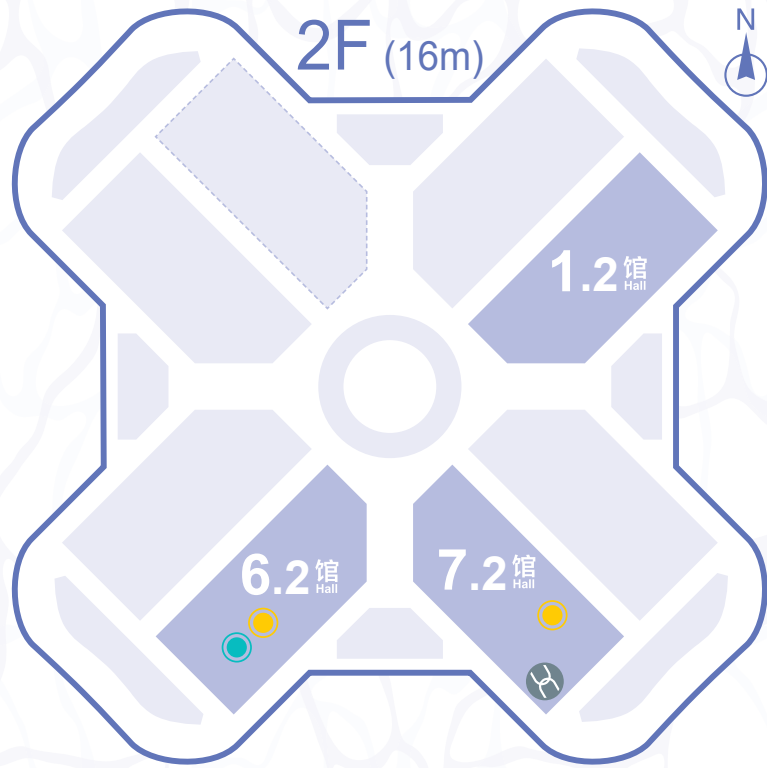

- 流行趋势  
Trend Forum
- 新技术创新空间  
Innotex Space
- 可持续创新专区  
Sustainability Zone
- 数字时尚创新空间  
Digital Fashion Innovation Space
- 萌宠时尚  
Pet Boutique
- 功能性产品展示区  
THE CUBE  
(Functional Lab)
- 传统色专题艺术展区  
Chinese Traditional Colors Art Exhibition
- 商贸洽谈区  
Business Matching Lounge
- 热点交流  
Talking Point
- 对话纺织  
Textile Dialogue
- 可持续发展论坛  
Economy Talks
- 数字化创新探索区  
Digital Innovation Exploration Space

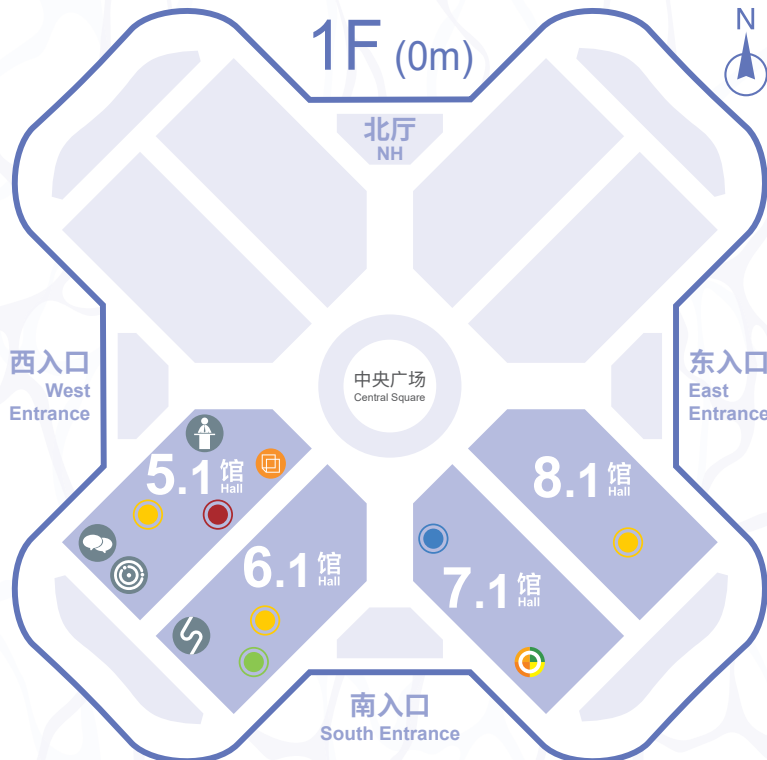

## 同期活动简介 FRINGE PROGRAMME INTRODUCTION

中国国际纺织面料及辅料（春夏）博览会的同期活动将横跨两天展期，以 4 大主题分类，聚焦及塑造服装及纺织贸易行业的未来。我们邀来行业专家及企业参与近 40 场研讨会及论坛分享，为买家及观众带来行业见解。

The two-day fringe programme is categorised into four key themes that shape the future of the apparel and textile trade industry. Industry experts and the fair's exhibitors will conduct around 40 seminars and panel discussions and themed forums to provide the latest trends and insights for exhibitors and buyers.

### 流行趋势 Design and Trends

国际知名的行业专家将进行多场研讨会及专题小组会议揭示 2027 春夏面料及色彩趋势。流行趋势发布区将通过面料展示与季节性潮流趋势全面揭示最新的设计趋势。

Internationally renowned industry specialists will offer various seminars and panel discussions to reveal 2027SS fabrics and colour trends. Comprehensive Trend Forums revealing the latest in design trends through fabric displays and seasonal trend stories also feature throughout the fair.

- Intertextile 2027 春夏流行趋势解析 Intertextile Trends Spring/Summer 2027 P 06
- 2027 春夏中国纺织面料流行趋势研讨会——面料趋势专场  
2027SS Fabrics China Trend Forum <esp. for fabrics trend> P 08

### 可持续发展议题 Econogy Talks

“Econogy”这个术语涵盖了在整个展会期间的所有可持续性主题活动。“Econogy”将经济和生态相结合，展示了可持续性对于企业的经济成功有多么关键。在可持续发展议题下，一系列研讨会和圆桌讨论将为您提供最新的可持续发展知识。

The term "Econogy" encompasses all the sustainability activities throughout the fair. Econogy summarises economy and ecology in one word and shows how crucial sustainability is for the economic success of a company today. Under the theme of Econogy Talks, a series of seminars and panel discussions will provide you with the latest sustainability knowledge.

- 共担·共治·共赢：纺织服装行业“责任链动”计划启动仪式  
Responsibility-Participation-Prosperity: Launch Event of the "Responsible Chain in Motion" Initiative for Textile and Apparel Industry P 10
- 可持续发展巡馆导览 Econogy Tour P 11
- 时尚新定义：废料就是新资源 Redefining Fashion: Waste Is the New Resource P 12

### 市场信息及营销策略 Market Information & Business Strategies

纺织行业的市场脉搏瞬息万变。如今，面料已远不止是服装的基础材料——它融合了时尚美学、功能科技与可持续理念，成为关键的创新载体。与此同时，蓬勃发展的宠物服装市场正开辟出新的蓝海，其中蕴藏着哪些亟待把握的行业先机？本届展会为您呈现一幅多元而立体的行业发展图景。

The textile market evolves rapidly. Today, fabric is far more than just the foundational material for garments—it integrates fashion aesthetics, functional technology, and sustainable concepts, becoming a key vehicle for innovation. Meanwhile, the booming pet clothing market is opening new frontiers. This exhibition delivers a comprehensive vision of the market's future landscape.

- 2026 徐州（上海）高端纺织产业投资推介会  
2026 Xuzhou (Shanghai) High-End Textile Industry Investment Promotion Conference P 13
- 毛孩时尚：探索宠物服装的创新与趋势 Beyond the Collar: Trends and Innovations in Pet Apparel P 14

### 技术 Technology and Solutions

展会期间将呈现一系列以纺织业的最新技术及创新科技为题的研讨会及论坛。2026 国际纺织产业数字化应用趋势论坛聚焦“数智纺织 绿色共生”展开讨论。系列产品开发也将围绕创新纺织技术、数字技术应用实践等探讨行业未来数字化转型方向。

A series of seminars and forums dedicated to the latest technologies and innovations in the textile industry will be featured during the exhibition. Among them, the 2026 International Textile Industry Digital Application Trend Forum will delve into the theme of "Digital & Intelligent Textiles, Green Symbiosis". Additionally, a series of product development sessions will explore the future direction of digital transformation within the sector, with a specific focus on innovative textile technologies and the practical applications of digital tools.

- “数智纺织 绿色共生”2026 国际纺织产业数字化应用趋势论坛  
Digital & Intelligent Textiles, Green Symbiosis  
2026 International Textile Industry Digital Application Trend Forum P 15
- 下一站新增长：面料产品开发的创新突破与场景引领  
Next Stop: New Growth | Innovative Breakthroughs and Application-Driven Fabric Product Development P 16
- 智链时尚：纺织行业数字化转型路径构建与实践应对  
Smart Chain Fashion: Path Construction and Practical Responses to Digital Transformation in the Textile Industry P 18
- COLORO TALK：时尚产业全链路色彩创新  
COLORO TALK: Color Innovation Across the Fashion Industry Ecosystem P 19

# 活动总览

## EVENT OVERVIEW

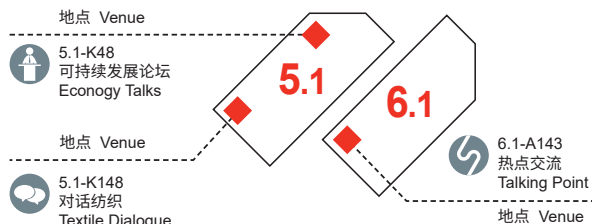

### 2026.3.11

时间 Time 地点 Venue	主题 Topic	企业 / 机构 Company / Institution	语言 Language
10:20 - 11:10 5.1-K148	逃离：开启新世界的大门 Escape: Opening the Door to a New World for Spring/Summer 2027	潘通色彩研究所 Pantone Color Institute	英语 * English*
10:35 - 11:05 5.1-K48	当可持续遇见时尚：GOTS 标签—— 纺织品可持续与公平的保障 Where Sustainability Meets Style: The GOTS Label - Assurance of Sustainability and Fairness in Textiles	Global Standard gGmbH	普通话 * Mandarin*
10:40 - 11:10 6.1-A143	双碳时代下的材料破局：海藻基生物材料的功能化创新与应用 Breakthrough of Materials in the Era of Dual Carbon: Functional Innovation and Application of Algae-based Biomaterials	山东海纤生物材料科技有限公司 Shandong Healcell Biomaterial Technology Co Ltd	普通话 Mandarin
11:10 - 11:40 5.1-K48	TE+GOTS 标准更新：MMS + GOTS 8.0 要点解析 TE+GOTS Standard Updates: Analysis of MMS & GOTS 8.0 Core Highlights	世优认证（上海）有限公司 Control Union Certification (Shanghai) Co Ltd	普通话 * Mandarin*
11:15 - 11:45 6.1-A143	生物基热塑性薄膜实践指引：源自自然，成就性能 A Practical Guide to Bio-based Thermoplastic Film: From Nature to Performance	浙江环龙新材料科技有限公司 Zhejiang Huanglong New Material Science & Technology Co Ltd	普通话 Mandarin
11:15 - 12:05 5.1-K148	Intertextile 2027 春夏流行趋势解析 Intertextile Trends Spring/Summer 2027	IS. Planning	日语 ** Japanese**
11:45 - 12:15 5.1-K48	可持续视角下的全球供应链追溯实践与能力建设 Sustainable Practice & Capability for Global Supply Chain Traceability	TextileGenesis (简称 TG 公司, 为 Lectra 旗下企业) TextileGenesis, a Lectra company	普通话 * Mandarin*
11:50 - 12:20 6.1-A143	认证助力纺织企业可持续发展和产品创新 Certification Supports Sustainable Development and Product Innovation in Textile Enterprises	中联品检（北京）技术集团有限公司 United Testing Services (Beijing) Technology Group Co Ltd	普通话 Mandarin
12:10 - 13:00 5.1-K148	27 春夏女装趋势 27SS Women's Trend	PeclersParis	英语 * English*
12:20 - 12:50 5.1-K48	2026 年 OEKO-TEX® 新规解析及 PFAS 监管重点 Analysis of the 2026 OEKO-TEX® New Regulations and Key Focus Areas in PFAS Oversight	海恩斯坦检测认证（上海）有限公司 Hohenstein Laboratories (Shanghai) Co Ltd	普通话 * Mandarin*
13:00 - 14:00 6.1-A143	论坛 Forum 2026 徐州（上海）高端纺织产业投资推介会 2026 Xuzhou (Shanghai) High-End Textile Industry Investment Promotion Conference	中国纺织工业企业协会 China Textile Enterprise Association	普通话 Mandarin
13:05 - 15:05 5.1-K48	论坛 Forum 共担·共治·共赢：纺织服装行业“责任链动”计划启动仪式 Responsibility-Participation-Prosperity: Launch Event of the "Responsible Chain in Motion" Initiative for Textile and Apparel Industry	中国纺织工业联合会社会责任办公室 Office for Social Responsibility, China National Textile and Apparel Council	普通话 * Mandarin*
13:05 - 13:55 5.1-K148	WGSN 2027 春夏女装面料趋势预测 Women's Textiles Forecast S/S 27	WGSN	普通话 * Mandarin*
14:00 - 16:30 5.1-K148	论坛 Forum 2027 春夏中国纺织面料流行趋势论坛 2027SS Fabrics China Trend Forum	中国纺织信息中心 China Textile Information Center	普通话 * Mandarin*
14:20 - 16:20 6.1-A143	论坛 Forum 下一站新增长：面料产品开发的创新突破与场景引领 Next Stop: New Growth   Innovative Breakthroughs and Application-Driven Fabric Product Development	中国纺织信息中心 China Textile Information Center	普通话 Mandarin
15:15 - 15:45 5.1-K48	塑造自然本真的美感：天丝™ 莱赛尔·HV100 纤维 Crafting Natural Imperfections TENCEL™ Lyocell-HV100: Our New Solution Mirroring Nature's Irregularities	兰精集团 Lenzing Group	普通话 * Mandarin*
15:55 - 16:25 5.1-K48	源于自然，赋能性能：再生涤纶与仿麻技术创新 Where Nature Inspires Performance: Circular Polyester and Linen-Like Innovation	苏州优富纺织品有限公司 Unifi Textiles (Suzhou) Co Ltd	普通话 * Mandarin*

16:25 - 16:55 6.1-A143	一直皱，烫不平——更松弛的「盐缩」肌理皱 Constantly Wrinkled, Impossible to Iron Flat —The More Relaxed "Salt-Shrink" Textured Silk	浙江凯喜雅国际股份有限公司 Zhejiang Cathaya International Co Ltd	普通话 Mandarin
16:35 - 17:05 5.1-K48	与染色醋酸纱线相比，原液染色醋酸纱线的优势 Advantages of Dope-Dyed Acetate Yarn Compared to Dyed Acetate Yarn	DP Acetate	普通话 * Mandarin*

### 2026.3.12

时间 Time 地点 Venue	主题 Topic	企业 / 机构 Company / Institution	语言 Language
10:20 - 11:50 5.1-K48	论坛 Forum 时尚新定义：废料就是新资源 Redefining Fashion: Waste Is the New Resource	法兰克福展览（香港）有限公司 Messe Frankfurt (HK) Ltd Redress	英语 * English*
10:30 - 13:00 5.1-K148	论坛 Forum 2027 春夏中国纺织面料流行趋势论坛 2027SS Fabrics China Trend Forum	中国纺织信息中心 China Textile Information Center	普通话 * Mandarin*
10:40 - 12:40 6.1-A143	论坛 Forum 智能时尚：纺织行业数字化转型路径构建与实践应对 Smart Chain Fashion: Path Construction and Practical Responses to Digital Transformation in the Textile Industry	中国纺织信息中心 China Textile Information Center	普通话 Mandarin
12:00 - 12:20 5.1-K48	经纬天下：全球纺织市场的全景探索与战略突围 Your Gateway to Global Textile Markets	法兰克福展览（香港）有限公司 Messe Frankfurt (HK) Ltd	英语 * English*
12:20 - 12:25 5.1-K48	Econogy Tour 巡馆导览 预热说明会 Econogy Tour Preview Session	法兰克福展览（香港）有限公司 Messe Frankfurt (HK) Ltd	英语 * English*
12:30 - 13:00 5.1-K48	从更高的时空维度看可持续发展 Sustainable Development in Higher Dimensions	上海瑞札新材料有限公司 Shanghai Ruizha New Materials Co Ltd	普通话 * Mandarin*
12:50 - 13:20 6.1-A143	福华世家 × 沃太能源——领航数字化工厂的绿色变革之路 Fuhua Weaving × Alpha ESS — Pioneering the Green Transformation Path of Digitalized Factories	沃太能源股份有限公司 Alpha ESS Co Ltd	普通话 Mandarin
13:15 - 14:15 5.1-K148	论坛 Forum 毛孩时尚：探索宠物服装的创新与趋势 Beyond the Collar: Trends and Innovations in Pet Apparel	法兰克福展览（香港）有限公司 Messe Frankfurt (HK) Ltd	普通话 * Mandarin*
13:25 - 14:55 5.1-K48	TESTEX 180 <sup>th</sup> Anniversary Special Event TESTEX 特思达 180 周年庆典活动	TESTEX 特思达	普通话 * Mandarin*
13:30 - 15:40 6.1-A143	论坛 Forum COLORO TALK: 时尚产业全链路色彩创新 COLORO TALK: Color Innovation Across the Fashion Industry Ecosystem	上海元彩科技有限公司 COLORO Co Ltd	普通话 * Mandarin*
14:50 - 15:20 5.1-K148	Naia™ Lyte: 伊士曼醋酸纤维带来全新轻薄突破 Eastman Naia™ Lyte Brings a Brand-new Breakthrough in Lightweight Textile Solutions	伊士曼（中国）投资管理有限公司 Eastman Chemical Company	普通话 * Mandarin*
15:10 - 15:40 5.1-K48	PFAS 全球管控趋势及循环经济合规解决方案 Global Trends in PFAS Regulation and Compliance Solutions for Circular Economy	SGS 通标标准技术服务有限公司 可持续纺织促进会 SGS-CSTC Standards Technical Services Co Ltd Textile Exchange	普通话 * Mandarin* 英语 * English*
15:30 - 17:30 5.1-K148	论坛 Forum “数智纺织 绿色共生” 2026 国际纺织产业数字化应用趋势论坛 Digital & Intelligent Textiles, Green Symbiosis 2026 International Textile Industry Digital Application Trend Forum	法兰克福展览（深圳）有限公司 Messe Frankfurt (Shenzhen) Ltd	普通话 * Mandarin*
15:50 - 16:20 5.1-K48	从愿景到合规：欧盟绿色协议如何重塑纺织业的生产者责任 From Vision to Compliance: How the European Green Deal is Reshaping Producer Responsibilities in the Textile Industry	北京爱科赛尔认证中心有限公司 Ecoert China	普通话 * Mandarin*
15:50 - 16:20 6.1-A143	内外之间，众行之履：2026 户外探索面料解决策略 Interface by Design: 2026 Technical Textiles for Collective Adventures	昆山东利新材料科技有限公司 Kunshan Doonly New Materials Technology Co Ltd	普通话 Mandarin
16:20 - 16:50 5.1-K48	海外市场纺织消费品监管动态解读 Review of Regulatory Updates for Textile Consumer Goods in Overseas Markets	天祥集团 Intertek	普通话 * Mandarin*
16:25 - 16:55 6.1-A143	焕彩新生·质启未来 Revitalizing with New Vibrance - Quality Initiates the Future	华孚时尚股份有限公司 Huafu Fashion Co Ltd	普通话 Mandarin

\* 提供普通话 ↔ 英语同声传译

\*\* 提供日语 ↔ 普通话交替传译

\* Mandarin ↔ English Simultaneous Interpretation will be provided

\*\* Japanese ↔ Mandarin & English Interpretation will be provided

## 重点活动 – 流行趋势

### FEATURED EVENTS – DESIGN AND TRENDS



#### 流行趋势展示区 5.1-E106 Trend Forum 5.1-E106

潮流导向委员会自 1998 年成立，委员会各成员来自世界各地的时尚之都，遍布欧洲、亚洲及美国等全球主要成衣出口市场，并致力为设计师及纺织业专才提供宝贵的市场研究及推广工具，协助他们紧贴未来的时装潮流而进行设计及生产。每一季，委员会都会结合彼此的专业知识和地区实力，利用展商所提交的面料以鲜明的主题刻画未来潮流及时装材料趋势。

The *Directions* Trend Committee was established in 1998, with committee members coming from fashion capitals of the major export markets for international garment trade: New York, Milan, Paris and Tokyo. The committee provides an invaluable research and marketing tool to designers and garment professionals, helping them steer their designs and manufacturing process in line with coming fashion seasons. Each season, they combine their expertise and local influences to come up with the themes that tell the story of tomorrow's apparel fabric trends and present at the Trend Forum through fabrics from exhibitors.

#### 2027 春夏季度主题：悖论

#### Spring/Summer 2027 Seasonal Theme: PARADOX

何为悖论？它看似矛盾难解……却往往能孕育新生。悖论在当今的诠释中，旨在以轻盈之姿、乐观之目光看待世界，以此唤醒消费的欲望，滋养心灵福祉。本季的悖论正是：敢于步入光明，焕新注入活力。

如今，时尚不再是彰显地位的勋章，更像是一场内观的旅程。它所倡导的自信并非源于完美无瑕，而是淬炼于简约、真实，乃至刻意留存的不完美、微妙的失调与被坦然接纳的瑕疵。它告别浮华喧嚣，转而颂扬个性与自由，并向经典致敬。这份对恒久、轻柔、和谐与宁静的承诺，能在纷繁潮流中唤醒我们敏锐的感知，最终沉淀为一种低调的优雅 — 它清新而精致，蕴藏着积极能量，并向世界敞开心怀。

#### 四大主题：

- 柔韧之悦
- 憩息写意
- 摄人芳华
- 礼赞匠心

What is a paradox? It is an apparent contradiction... yet one from which a new solution can emerge. In today's context, it is about bringing forth lightness, casting an optimistic gaze upon the world, rekindling the consumer's desire, and nurturing a sense of well-being. Daring to step into the light: that is the paradox of the season, generating a fresh new dynamic.

Less about status and more about contemplation, fashion fosters self-confidence not through perfection, but through simplicity, authenticity, even deliberate imperfections, subtle dissonance, or embraced mistakes. Breaking away from excess and spectacle, it highlights individuality and freedom, while inviting us to revisit the archives. A pledge of durability and a slow pace, as well as harmony and serenity, this journey revives sensitivity across today's trends — a discreet elegance that settles with freshness and delicacy, yet also with positive energy and openness to the world.

#### Four themes will be presented:

- AFFECTION
- BREATHE
- BEWITCHING
- HONOURATION



## 重点活动 – 流行趋势

### FEATURED EVENTS – DESIGN AND TRENDS



#### Intertextile 流行趋势讲解 Intertextile Trend Introduction



2027 年春夏潮流趋势之首席设计师是来自日本的井上佐知子女士，她将全面介绍 Intertextile 流行趋势，包括各种面料的设计与潮流趋势。

The designer of the Intertextile *Directions* Trend Forum for Spring/Summer 2027 is Sachiko Inoue from Japan. She will introduce the Intertextile Trends, the latest design trends and seasonal trend stories.

#### 2026.3.11

- 11:15 - 12:05  
🗨️ 5.1-K148 Intertextile 2027 春夏流行趋势解析  
Intertextile Trends Spring/Summer 2027
- 13:00 - 13:30  
📍 5.1-E106 流行趋势讲解 – 第一节  
Trend Forum Introduction Tour - Session 1
- 15:30 - 16:00  
📍 5.1-E106 流行趋势讲解 – 第二节  
Trend Forum Introduction Tour - Session 2

#### 2026.3.12

- 11:00 - 11:30  
📍 5.1-E106 流行趋势讲解 – 第三节  
Trend Forum Introduction Tour - Session 3

\* 提供普通话 ↔ 英语同声传译

\*\* 提供日语 ↔ 普通话 & 英语翻译

\* Mandarin ↔ English Simultaneous Interpretation will be provided

\*\* Japanese ↔ Mandarin & English Interpretation will be provided

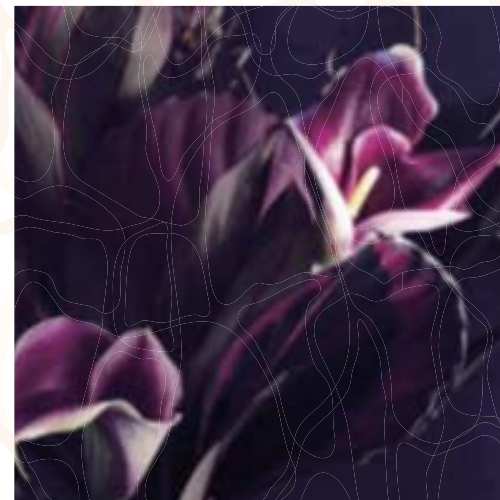

# 重点活动 – 流行趋势

## FEATURED EVENTS – DESIGN AND TRENDS

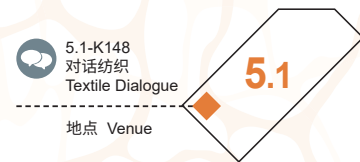

### 2027 春夏中国纺织面料流行趋势研讨会 ——面料趋势专场 2027SS Fabrics China Trend Forum <esp. for fabrics trend>

### 论坛 FORUM



中国纺织面料流行趋势研究结合市场需求，系统化研究色彩、纤维、纱线、面料服装风格、技术以及产品开发方向，运用趋势研究的国际化、专业化和市场化研究力量，指导企业进行精准的趋势应用与产品推广。此次系列趋势论坛演讲嘉宾由中国纺织信息中心流行趋势研究专家、分品类趋势联盟研究专家组成，以 2027 春夏中国纺织面料流行趋势为引领，结合纺织服装产业链的终端需求，在产品开发、产品企划以及生产实践等多维度进行系统化阐述，展示中国纺织面料流行趋势及分品类趋势的研究成果。

Based on market demand, Fabrics China trend research gathers international, professional, and market-oriented research resources to systematically study colors, fibers, yarns, fabrics, apparel styles, technologies, and product development directions, so as to guide enterprises to promote new products on the basis of latest trends application. The speakers of this forum are trend research experts from China Textile Information Center and sub-category trend alliances. Combining the needs of the textile and apparel industry chain, experts will elaborate on product development, product planning, and production practice based on the SS 2027 Fabrics China trend research, showing related research results and category trends.

- 国内流行趋势区:  
6.1 号馆 可持续时尚流行趋势区 (6.1-E80)  
6.2 号馆 科技 & 功能流行趋势区 (6.2-E108)  
7.2 号馆 牛仔流行趋势区 (7.2-E105)  
8.1 号馆 时尚概念流行趋势区 (8.1-E105)

- 国内特色展示区:  
7.1 号馆 数字时尚创新空间 (7.1-E12)  
6.1 号馆 可持续创新专区 (6.1-H106)  
6.2 号馆 新技术创新空间 (6.2-E122)

- Domestic Trend Forums:  
6.1H Sustainable Fashion Trend Forum (6.1-E80)  
6.2H Techno & Functions Trend Forum (6.2-E108)  
7.2H Denim Trend Forum (7.2-E105)  
8.1H Fashion Focus Trend Forum (8.1-E105)

- Domestic Featured Display Areas:  
7.1H Digital Fashion Innovation Space (7.1-E12)  
6.1H Sustainability Zone (6.1-H106)  
6.2H Innotech Space (6.2-E122)

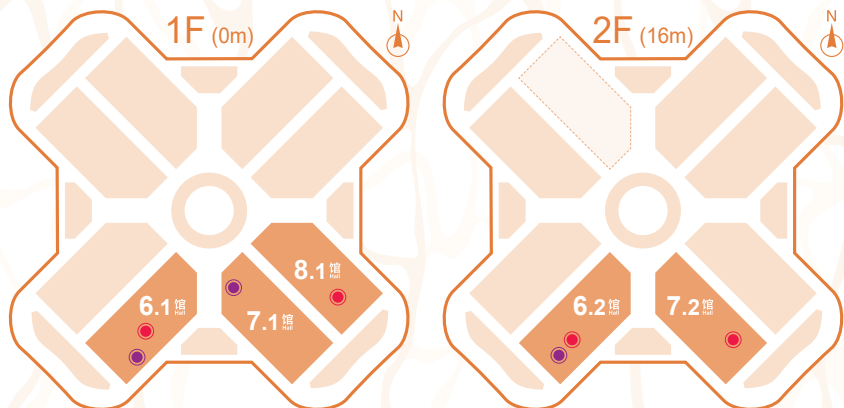

### 2026.3.11

时间 Time	议程 Schedule	讲者 Speakers
14:00 - 14:40	2027 春夏中国纺织面料流行趋势 SS 2027 Fabrics China Trend	李晓菲, 中国纺织信息中心, 流行趋势部主任 Xiaofei Li, Trend Dept. Director, China Textile Information Center
14:40 - 15:20	2027 春夏中国艺术染整流行趋势发布 Chinese Dyeing & Finishing Trend of SS 2027	艺术染整与现代扎染流行趋势研究中心 罗竞杰, 东华大学服装与艺术设计学院, 服装与服饰专业负责人; 东华·江苏华艺艺术染整科技创新中心主任 Fabrics China Trend Research Center - Artistic Dyeing & Finishing and Modern Tie Dyeing Luo Jingjie, Director of Apparel & Accessories Dept, College of Fashion and Design of Donghua University; Director of Donghua· Jiangsu Huayi Artistic Dyeing & Finishing Innovation Research Center
15:20 - 16:00	开发驱动, 生态共生——德州华源的 差异化纱线创新实践 Development-driven, Ecological Coexistence: Dezhou Huayuan's Practice of Differentiated Yarn Innovation	差别化功能性色纺纱流行趋势研究中心 艾英杰, 德州华源生态科技有限公司, 产品经理 Fabrics China Trend Research Center - Functional Colored Spun Yarn Yingjie Ai, Product Manager, Dezhou Huayuan Eco-Technology Co Ltd
16:00 - 16:30	直击库存痛点: 生物基染料如何破解 牛仔黄变难题与实现库存保值 Tackling Inventory Pain Points: How Bio-based Dyes Solve Denim Yellowing for Long-Term Value	徐富超, Chloris, 首席技术官 Fuchao Xu, CTO, Chloris

### 2026.3.12

时间 Time	议程 Schedule	讲者 Speakers
10:30 - 11:00	2027 春夏中国纺织面料流行趋势—— 色彩流行趋势解析 SS 2027 Fabrics China Trend - Color Trend	王玢, 中国纺织信息中心流行趋势部高级趋势研究员; FASHION INSIGHT 编辑 Bin Wang, Senior Trend Researcher of Trends Department, China Textile Information Center; Editor of FASHION INSIGHT
11:00 - 11:30	山东联润: 紧柔纺® 专利技术解锁时 尚与机能的无限融合 Shandong Long Run: Sirofil- Compact Spinning® — Unlock infinite integration of fashion and function	纺织新材料纱线流行趋势研究中心 朱培, 山东联润新材料科技有限公司, 总经理助理 Fabrics China Trend Research Center - New Fiber-based Yarn Pei Zhu, Executive Assistant to the General Manager, Long Run Textile Co Ltd
11:30 - 12:00	江苏丹毛 2027 春夏趋势面料分享 SS 2027 Trend Fabric Sharing — Danmao	女装精毛纺面料流行趋势研究中心 花香, 江苏丹毛纺织股份有限公司, 针织产品开发经理 Fabrics China Trend Research Center - Worsted Textiles for Womenswear Hua Xiang, Knitted Product Development Manager, Jiangsu Danmao Textile Co Ltd
12:00 - 12:30	鲁泰集团 2027 春夏新品趋势 Luthai Group's 2027 Spring & Summer New Product Trends	色织面料流行趋势研究中心 孙艳柳, 鲁泰纺织股份有限公司, 设计师 Fabrics China Trend Research Center - Yarn dyed Textiles Yanliu Sun, Designer, Luthai Textile
12:30 - 13:00	精工深耕·价值共生——纬一的产品 矩阵和创新实践 Precision Craftsmanship & Deep Cultivation • Value Symbiosis — Weiyi's Product Matrix and Innovative Practices	人造皮革流行趋势研究中心 胡梦婷 / 宁波纬一长毛绒有限公司 / 趋势中心 Fabrics China Trend Research Center - Artificial Fur Mengting Hu, Trend Center, Ningbo Weiyi Plush Co Ltd

\* 提供普通话 ↔ 英语同声传译  
\* Mandarin Chinese ↔ English Simultaneous Interpretation will be provided

## 重点活动 – 可持续发展议题

### FEATURED EVENTS – ECONOGY TALKS



**共担·共治·共赢：纺织服装行业“责任链动”计划启动仪式**  
**Responsibility-Participation-Prosperity: Launch Event of the "Responsible Chain in Motion" Initiative for Textile and Apparel Industry**

**论坛  
FORUM**



**2026.3.11**

时间 Time	议程 Schedule	讲者 Speakers
13:05 - 13:25	<p>开场致辞 Opening Remarks 以责任促合作，以能力赢未来 Building Trust through Responsibility, Shaping Tomorrow through Capability</p> <p>开场致辞 Opening Remarks 将愿景付诸行动：负责任供应链的工具与洞见 Bridging Vision with Action: Insights and Tools for Responsible Supply Chains in China</p> <p>开场致辞 Opening Remarks 从合规到引领：携手共建面向未来的供应链 From Compliance to Leadership: Partnering for a Future-Ready Supply Chain</p>	<p>梁晓晖，中国纺织工业联合会社会责任办公室首席研究员 Xiaohui Liang, Chief Researcher, Office for Social Responsibility, China National Textile and Apparel Council</p> <p>Peter Higgins，经济合作与发展组织（OECD）负责任商业行为中心鞋服项目经理 Peter Higgins, Programme Manager, Garment and Footwear Sector, OECD Centre for Responsible Business Conduct</p> <p>Linda KROMJONG，全球贸易协会（amfori）总裁 Linda KROMJONG, Director, amfori</p>
13:25 - 13:45	<p>主题演讲 Keynote Speech 尽责管理调研成果发布与“责任链动”计划推介 Release of Due Diligence Research Findings and Introduction of the "Responsible Chain in Motion" Initiative</p>	<p>王静，中国纺织工业联合会社会责任办公室研究员 Jing Wang, Researcher, Office for Social Responsibility, China National Textile and Apparel Council</p>
13:45 - 13:55	<p>纺织服装行业“责任链动”计划启动仪式 Launch Event of the "Responsible Chain in Motion" Initiative for Textile and Apparel Industry</p>	

13:55 - 14:55	<p>全球协作，共筑负责任的纺织价值链 Partner Collaboration to Co-Create a Responsible Textile and Apparel Value Chain</p> <p>超越审核，为负责的行动伙伴赋能 Empowering Responsible Action Partners Beyond Audits</p> <p>担当新角色，做责任的“翻译官” Taking on a New Role and Acting as the "Translator" of Responsibility</p> <p>源头把控，为产品铺就负责任底色 Controlling at Source to Lay a Responsible Foundation for the Product</p>	<p>李兆康，amfori，东亚及太平洋总监 Hong Lee, Director East Asia &amp; Pacific, amfori</p> <p>黄翠琪，安踏集团，可持续发展 / 投资者关系高级总监 Suki Wong, Senior Director - Corporate ESG &amp; IR, Anta Sports</p> <p>徐皖，H&amp;M，合作伙伴关系及公共事务副总裁 Erin Xu, Vice President, Partnership and Public Affairs, H&amp;M</p> <p>姜延慧，恒田企业，副总裁 Yanhui Jiang, Vice President, HANDA Group</p>
14:55 - 15:05	<p>会议总结 Closing Remarks</p>	<p>阎岩，中国纺织工业联合会副会长、社会责任办公室主任；国际纺织制造商联合会（ITMF）副主席 Yan Yan, Vice President, China National Textile and Apparel Council, Director of Office for Social Responsibility of CNTAC; Vice President, International Textile Manufacturers Federation (ITMF)</p>

\* 提供普通话 ↔ 英语同声传译  
\* Mandarin Chinese ↔ English Simultaneous Interpretation will be provided

### 可持续发展巡馆导览 Econogy Tour

在一小时的 Econogy Tour 巡馆导览中将有一名独立顾问带大家拜访拥有环保标签及认证的参展企业。参与导览的观众可以与参展商及专家在绿色纺织创新的议题上进行深入交流。导览前更设有预热会，由巡馆导览的专家 Karl Borgschulze 为您进行前瞻讲解，提前梳理重点，帮助您最大化巡馆收获。

日期：3月12日  
预热会时间：12:20 - 12:25  
导览时间：12:25 - 13:25  
集合地点：5.1-K48 可持续发展论坛场地外

The one-hour Econogy Tour to sustainability-focused exhibitors is guided by an independent consultant, enabling an in-depth exchange on the latest green textile innovations. Prior to the tour, a preview session will be held where our expert tour guide Karl Borgschulze will provide forward-looking insights, highlight key points in advance, and help you maximise your visit experience.

Date: 12 March  
Preview Session: 12:20 - 12:25  
Tour Time: 12:25 - 13:25  
Meeting Point: Outside Econogy Talks (5.1-K48)

\* 无需登记即可参加导览。  
\* Registration is not required to join the tour.



## 重点活动 – 可持续发展议题

### FEATURED EVENTS – ECONOGY TALKS

时尚新定义：废料就是新资源  
Redefining Fashion: Waste Is the New Resource

论坛  
FORUM



intertextile  
SHANGHAI apparel fabrics



12.3.2026  
10:20 – 11:50



本次专题讨论将探讨循环时尚的演变及发展 — 从创意及设计实践到原材料采购和制造，以适应不断变化的纤维产业格局。嘉宾将深入分析品牌如何与设计师合作，重新思考资源利用方式，打造将废弃物转化为资源而非负担的系列产品，以及新一代可持续材料如何在超越升级再造的变革中发挥关键作用。

This panel will explore how circular fashion is evolving – from creative / design practice through to sourcing and manufacturing – to accommodate a changing landscape in fibres. We'll dig into how brands can collaborate with designers, rethink resources, and build collections where waste becomes material, not a problem and how next-generation sustainable materials play a part enabling this shift beyond upcycling.

#### 2026.3.12

时间 Time	议程 Schedule	讲者 Speakers
10:20 - 10:30	开幕辞 Opening Remarks	Nissa Cornish, Redress, 执行总监 Nissa Cornish, Executive Director, Redress
10:30 - 11:35	圆桌讨论 Panel Discussion	主持人 Moderator Nissa Cornish, Redress, 执行总监 Nissa Cornish, Executive Director, Redress  对话嘉宾 Panelists Carla Zhang, Le Ngok, 创始人及创意总监及 2025 年度 "Redress 设计大赛" 大奖得主 Eva Engelen, Fashion for Good, 创新经理 田如茵, Sunday Square, 创始人及 2024 年度 "Redress 设计大赛" 优异奖得主 姚雅文博士, 超级皮儿, 研发总监 Carla Zhang, Founder & Creative Director, Le Ngok & Redress Award 2025 Winner Eva Engelen, Innovation Manager, Fashion for Good Ruyin Tian, Founder, Sunday Square & Redress Design Award 2024 Runner-up Dr. Yawen Yao, R&D Director, PEELSPHERE
10:35 - 11:50	自由问答环节 Audience Q&A	

\* 提供普通话 ↔ 英语同声传译

\* Mandarin Chinese ↔ English Simultaneous Interpretation will be provided

## 重点活动 – 市场信息及营销策略

### FEATURED EVENTS – MARKET INFORMATION & BUSINESS STRATEGIES

2026 徐州（上海）高端纺织产业投资推介会  
2026 Xuzhou (Shanghai) High-End Textile  
Industry Investment Promotion Conference

论坛  
FORUM

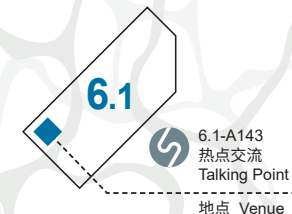

#### 2026.3.11

时间 Time	议程 Schedule	讲者 Speakers
13:00 - 13:05	开场介绍 Opening Introduction	
13:05 - 13:15	徐州市政府领导致辞并推介 Speech and Presentation by the Leader of Xuzhou Municipal Government	
13:15 - 13:20	中国纺织工业联合会领导致辞 Speech by China National Textile and Apparel Council (CNTAC) Leadership	
13:20 - 13:30	沛县专题推介：全链协同 经纬交织——推动沛县纺织产业全产业链创新发展 Peixian County Special Presentation: Full-Chain Coordination & Interwoven Development — Promoting the Innovative Development of the Full Industrial Chain of Peixian's Textile Industry	刘一, 沛县县委副书记、县长 Yi Liu, Deputy Secretary of the Peixian County Party Committee and County Mayor
13:30 - 13:40	睢宁县专题推介：聚焦链群协同发展 共创纺织新未来 Suining County Special Presentation: Focus on the Synergistic Development of Industrial Chains and Clusters, Jointly Create a New Future for the Textile Industry	杨远朝, 睢宁县县委副书记、县长 Yuanchao Yang, Deputy Secretary of the Suining County Party Committee and County Mayor
13:40 - 13:50	新沂市专题推介：聚焦“产业协同”、聚力打造高端纺织产业新高地 Xinyi City Special Presentation: Focusing on "Industrial Synergy", Striving to Build a New Highland for High-End Textile Industry	陈琳, 新沂市委副书记、市长 Lin Chen, Deputy Secretary of the Xinyi County Party Committee and County Mayor
13:50 - 13:55	在徐投资高端纺织重点企业代表发言 Remarks from Key High-End Textile Enterprises with Operations in Xuzhou	龚正晖, 徐州普路通纺织科技有限公司董事长 Zhenghui Gong, Chairman of Xuzhou Pulutong Textile Technology Co Ltd
13:55 - 14:00	合作项目展示 Cooperative Project Showcase	

## 重点活动 – 市场信息及营销策略

### FEATURED EVENTS – MARKET INFORMATION & BUSINESS STRATEGIES

毛孩时尚：探索宠物服装的创新与趋势  
Beyond the Collar: Trends and Innovations  
in Pet Apparel



与我们共同探索宠物服装市场的迷人世界！顶级审计公司 KPMG 将分享最新的市场趋势，帮助您把握行业脉动。全球领先纤维生产商兰精集团将展示创新材料，兼顾功能与可持续性。本次论坛将揭示宠物和主人在服装选择上的真实需求。把握宝贵机会，确保您的品牌在不断发展的宠物时尚世界中保持领先地位！

Embark on a captivating journey into the pet apparel market at our engaging panel discussion! Hear from top global auditing organization – KPMG who will highlight the latest market trends. Discover cutting-edge material innovations from leading fabric manufacturers – Lenzing Group that enhance both functionality and sustainability. This forum will spill the tea on what pets and their owners are really looking for in apparel. This is your chance to gather invaluable insights, ensuring your brand stays ahead in the ever-evolving pet fashion world!

#### 2026.3.12

时间 Time	议程 Schedule	讲者 Speakers
13:15 - 13:45	2025 年中国宠物行业市场报告 2025 China Pet Industry Market Report	刘婉婷, 毕马威中国, 零售及消费品行业合伙; 2025 中国宠物行业市场报告组委会主席 Sherry Liu, Partner of Consumer & Retail, Partner-in-charge of 2025 Pet Industry Report, KPMG China
13:45 - 14:15	环保天丝™, 和谐宠护 Green TENCEL™, Pets Protection	王艳民, 功能性产品市场拓展经理, 兰精集团 Fred Wang, BD Manager, Functional Wear, Lenzing Group

\* 提供普通话 ↔ 英语同声传译

\* Mandarin Chinese ↔ English Simultaneous Interpretation will be provided

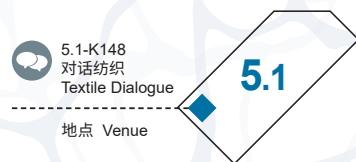

论坛  
FORUM

## 重点活动 – 技术

### FEATURED EVENTS – TECHNOLOGY AND SOLUTIONS

“数智纺织 绿色共生”  
2026 国际纺织产业数字化应用趋势论坛  
Digital & Intelligent Textiles, Green Symbiosis  
2026 International Textile Industry Digital  
Application Trend Forum



在全球纺织工业迈向以“人工智能”与“绿色可持续发展”为双核心的产业升级新阶段，数字化转型已成为构建全球竞争力的关键支柱。为深度解析前沿技术路径、促进国际经验与本土实践融合，2026 国际纺织产业数字化应用趋势论坛（春夏）将构建一个前瞻性、战略性及务实性并重的行业高端对话平台。

As the global textile industry enters a new phase of industrial upgrading with "Artificial Intelligence" and "Green Sustainable Development" as its dual cores, digital transformation has become a key pillar for building global competitiveness. To deeply analyse cutting-edge technology paths and promote the integration of international experience with local practices, the 2026 International Textile Industry Digital Application Trend Forum (Spring & Summer) will build a high-end industry dialogue platform that emphasises forward-looking, strategic, and practical perspectives.

#### 2026.3.12

时间 Time	议程 Schedule	讲者 Speakers
15:30 - 15:40	开幕致辞 Opening Speech	余诗慧, 法兰克福展览 (香港) 有限公司, 总经理 Wilmet Shea, General Manager, Messe Frankfurt (HK) Ltd
15:40 - 16:00	产品数字护照 (DPP) 的中国实践与全球合规 Product Digital Passport (DPP): China's Practices and Global Compliance	胡柯华, 中国纺织工业联合会社会责任办公室副主任 Kehua Hu, Deputy Director of the Social Responsibility Office, China National Textile and Apparel Council (CNTAC)
16:00 - 16:20	人工智能 + 纺织产业的现状和趋势 Current State and Trends of AI in the Textile Industry	喻波, 深圳市智能制造产业促进会联席会长 Bo Yu, Co-Chairman of Shenzhen Association for the Promotion of Intelligent Manufacturing Industry
16:20 - 16:40	从合规到能力: 新形势下的全球供应链追溯 From Compliance to Capability: Supply Chain Traceability in a New Landscape	陈德宏, TextileGenesis (简称 TG 公司, 为 Lectra 旗下企业), 东亚区总监 Simon Chen, Regional Director, East Asia, TextileGenesis, a Lectra company
16:40 - 17:00	人工智能技术赋能纺织印染行业高质量发展 Artificial Intelligence Technology Empowers the High-quality Development of the Textile Printing and Dyeing Industry	罗玉成, 绍兴市柯桥织造印染产业大脑运营有限公司, 副总经理 Yucheng Luo, Deputy General Manager of Shaoxing Keqiao Weaving, Printing and Dyeing Industry Brain Operation Co Ltd
17:00 - 17:30	圆桌会议 Panel Discussion 人工智能与绿色数字化——纺织产业的技术融合路径与产业实践 AI and Green Digitalisation: Technology Integration Pathways and Industry Practices in the Textile Sector	

\* 提供普通话 ↔ 英语同声传译

\* Mandarin Chinese ↔ English Simultaneous Interpretation will be provided



论坛  
FORUM

## 重点活动 – 技术

### FEATURED EVENTS – TECHNOLOGY AND SOLUTIONS

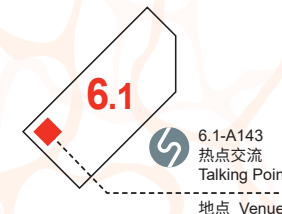

下一站新增长 | 面料产品开发的创新突破与场景引领  
Next Stop: New Growth | Innovative Breakthroughs and Application-Driven Fabric Product Development

论坛  
FORUM



本论坛聚焦中国流行面料优选企业的创新实践，围绕“创新突破与场景引领”，以多元案例展示如何通过技术迭代、产品创新和场景深耕，有效响应新消费市场的多样化和碎片化需求，解决品牌升级、产品差异化等行业痛点，助力企业抢占市场先机，实现商业价值突破。

Focusing on the innovative practices of Fabrics China flagship enterprises, this forum centers on "Innovative Breakthroughs and Application-Driven Development". Through diverse case studies, it demonstrates how technology upgrades, product innovation, and application-driven approaches effectively address the diversified and fragmented demands of the new consumer market, solve industry pain points such as brand upgrading and product differentiation, and help enterprises seize market opportunities to unlock new commercial value.

#### 2026.3.11

时间 Time	议程 Schedule	讲者 Speakers
14:20 - 14:40	差异化赋能·锦纶功能纤维驱动品牌可持续发展 Innovative Differentiation: How Functional Nylon Fibers Empower Sustainable Brand Growth	缪恬, 福建永荣锦江股份有限公司, 品牌经理 Tian Miao, Brand Manager of Brand and Commercial Department, Fujian Yongrong Jinjiang Co Ltd
14:40 - 15:00	蝴蝶缎·从 AI 技术到未来跨界新物种 Butterfly Satin: An Interdisciplinary New Species from AI Technology to Connecting the Future	蒋璐, 凯喜雅智纺科技有限公司, 总经理 Lu Jiang, General Manager, Zhejiang Cathaya Intelligent Textile Technology Co Ltd
15:00 - 15:20	新潮牛仔·面料创新驱动多元应用场景突破 Trendsetting Denim: Breakthroughs in Fabric Innovation for Diverse Applications	涂强, 广州市谊兴纺织有限公司, 品牌营销总监 Qiang Tu, Brand Marketing Director, Guangzhou Winwin Textile Co Ltd
15:20 - 15:40	场景聚焦·针织休闲面料的品类创新与市场共振 Scenario-Driven Innovation: Category Upgrades and Market Resonance in Knitted Casual Fabrics	刘阳, 东莞德永佳纺织制衣有限公司, 推广部负责人 Yang Liu, Promotion Department Director, Dongguan Texwinca Textile & Garment Limited
15:40 - 16:00	裤装新故事·品牌服务驱动产品与营销再升级 New Narratives in Trousers: Customer-Centric Product and Marketing Innovations	王堃, 广州帛璟纺织品有限公司, 总经理 Kun Wang, General Manager, Guangzhou Bojing Textile Co Ltd
16:00 - 16:20	跨界羊毛·时尚女装与功能运动品类的创新应用 Wool Reimagined: Innovative Applications in Fashion Womenswear and Functional Sportswear	赵丽萍, 浙江富润纺织有限公司, 开发部部长 Liping Zhao, Director of Development Department, Zhejiang Furun Textile Co Ltd

## 重点活动 – 技术

### FEATURED EVENTS – TECHNOLOGY AND SOLUTIONS



论坛  
FORUM

智链时尚：纺织行业数字化转型路径构建与实践应对  
Smart Chain Fashion: Path Construction and Practical Responses to Digital Transformation in the Textile Industry



聚焦纺织行业数字化转型中核心痛点，搭建纺织行业数字化转型高效交流平台。通过拆解转型关键环节、输出可复用的成熟方案，助力纺织行业上下游企业明晰转型方向、少走弯路，有效降低数字化探索成本，加速实现生产智能化升级、管理流程高效化优化、运营模式柔性化创新，赋能企业在行业变革中抢占发展先机。

Focusing on the core pain points in the digital transformation of the textile industry, this event aims to build an efficient communication platform for the sector's digital transformation. By dissecting key transformation links and delivering reusable mature solutions, it assists upstream and downstream enterprises in the textile industry to clarify transformation directions, avoid detours, effectively reduce the cost of digital exploration, and accelerate the intelligent upgrading of production, efficient optimisation of management processes, and flexible innovation of operational models. Ultimately, it empowers enterprises to seize development opportunities amid industry changes.

#### 2026.3.12

时间 Time	议程 Schedule	讲者 Speakers
10:40 - 11:10	纺织百分制 品控新标准——MyTexAI 驱动纺织产业链升级新范式 Textile100 New QC Standard — MyTex AI-Powered Textile Chain Upgrade Paradigm	阙右根, 美泰克斯 (苏州) 科技有限公司, 总经理 Yougen Que, General Manager, MyTex (Suzhou) Technology Co Ltd
11:10 - 11:40	数据驱动染色革命, 绿色智造赋能纺织生态 Data-Driven Dyeing Revolution, Green Intelligent Manufacturing Empowering Textile Ecosystem	殷珉, 杭州环峪数智科技有限公司, 供应链总监 Min Yin, Supply Chain Director, Valley Delta (Huanyu Technology)
11:40 - 12:10	AI 视觉检测赋能纺织瑕疵零缺陷 AI Visual Inspection Empowers Zero Defects in Textile Flaw Detection	吕慧明, 南通巨联数字科技有限公司, 机器视觉产品高级经理 Huiming Lv, Senior Manager of Machine Vision Products, Nantong Julian Digital Technology Co Ltd
12:10 - 12:40	以标促建, 数智赋能 Build with Standards, Empower with Digital Intelligence	许展瑜, 中国纺织信息中心, 时尚智能部项目经理 Zhanyu Xu, Project Manager, Fashion Intelligence Dept., China Textile Information Center

## 重点活动 – 技术

### FEATURED EVENTS – TECHNOLOGY AND SOLUTIONS

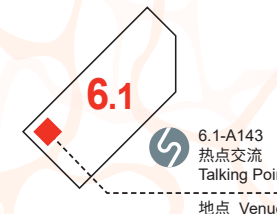

论坛  
FORUM

COLORO TALK: 时尚产业全链路色彩创新  
COLORO TALK: Color Innovation Across the Fashion Industry Ecosystem



#### 2026.3.12

时间 Time	议程 Schedule	讲者 Speakers
13:30 - 14:10	27 春夏运动户外趋势色彩解析 2027SS Active & Outdoor Color Trend	王刘莹, COLORO, 色彩项目总监 Liuqing Wang, Color Project Director, COLORO
14:10 - 14:55	纺织服装品牌的色彩供应链管理探讨 Color Supply Chain Management for Textile and Apparel Brands	米曦, COLORO, 副总经理 Mi Xi, Deputy Managing Director, COLORO
14:55 - 15:40	全链路色彩复现: 为品牌“制造”色彩的确 定性 End-to-End Color Reproducibility: Ensuring Color Certainty for Brands	彭无恙, Datacolor, 大区客户经理 Blake Peng, Key Account Manager, Datacolor

\* 提供普通话 ↔ 英语同声传译

\* Mandarin Chinese ↔ English Simultaneous Interpretation will be provided

# 活动总览 – 流行趋势

## EVENT SCHEDULE – DESIGN AND TRENDS

5.1-K148  
对话纺织  
Textile Dialogue  
地点 Venue

5.1

### 2026.3.11

时间 Time 地点 Venue	主题 Topic	讲者 Speakers	语言 Language
10:20 - 11:10 5.1-K148	<b>研讨会 Seminar</b> 逃离：开启新世界的大门 Escape: Opening the Door to a New World for Spring/Summer 2027	Laurie Pressman, 潘通色彩研究所, 副总裁 Laurie Pressman, Vice President, Pantone Color Institute	英语 * English*
11:15 - 12:05 5.1-K148	<b>研讨会 Seminar</b> Intertextile 2027 春夏流行趋势解析 Intertextile Trends Spring/Summer 2027	井上佐知子, IS. Planning, 趋势总监 Sachiko Inoue, Trend Director, IS. Planning	日语 ** Japanese**
12:10 - 13:00 5.1-K148	<b>研讨会 Seminar</b> 27 春夏女装趋势 27SS Women's Trend	Benedicte Peaudecerf, PeclersParis, 风格与趋势 研究设计师 Benedicte Peaudecerf, Style Designer and Trend Forecaster, PeclersParis	英语 * English*
13:05 - 13:55 5.1-K148	<b>研讨会 Seminar</b> WGSN 2027 春夏女装面料趋势预测 Women's Textiles Forecast S/S 27	门淑萍, WGSN, 趋势总监 Maggie Men, Trends Director, WGSN	普通话 * Mandarin*
14:00 - 14:40 5.1-K148	<b>论坛 Forum</b> 2027 春夏中国纺织面料流行趋势 2027SS Fabrics China Trend	李晓菲, 中国纺织信息中心, 流行趋势部主任 Xiaofei Li, Trend Dept. Director, China Textile Information Center	普通话 * Mandarin*
14:40 - 15:20 5.1-K148	<b>论坛 Forum</b> 2027 春夏中国艺术染整流行趋势发布 Chinese Dyeing & Finishing Trend of SS 2027	艺术染整与现代扎染流行趋势研究中心 罗竞杰, 东华大学服装与艺术设计学院, 服装与服饰专业负责人; 东华·江苏华艺艺术染整科技创新中心主任 Fabrics China Trend Research Center - Artistic Dyeing & Finishing and Modern Tie Dyeing Luo Jingjie, Director of Apparel & Accessories Dept, College of Fashion and Design of Donghua University; Director of Donghua · Jiangsu Huayi Artistic Dyeing & Finishing Innovation Research Center	普通话 * Mandarin*
15:20 - 16:00 5.1-K148	<b>论坛 Forum</b> 开发驱动, 生态共生——德州华源的差异化纱线创新实践 Development-driven, Ecological Coexistence: Dezhou Huayuan's Practice of Differentiated Yarn Innovation	差别化功能性色纺纱流行趋势研究中心 艾英杰, 德州华源生态科技有限公司, 产品经理 Fabrics China Trend Research Center - Functional Colored Spun Yarn Yingjie Ai, Product Manager, Dezhou Huayuan Eco-Technology Co Ltd	普通话 * Mandarin*
16:00 - 16:30 5.1-K148	<b>论坛 Forum</b> 直击库存痛点: 生物基染料如何破解牛仔黄变难题与实现库存保值 Tackling Inventory Pain Points: How Bio-based Dyes Solve Denim Yellowing for Long-Term Value	徐富超, Chloris, 首席技术官 Fuchao Xu, CTO, Chloris	普通话 * Mandarin*

### 2026.3.12

时间 Time 地点 Venue	主题 Topic	讲者 Speakers	语言 Language
10:30 - 11:00 5.1-K148	<b>论坛 Forum</b> 2027 春夏中国纺织面料流行趋势——色彩流行趋势解析 SS 2027 Fabrics China Trend - Color Trend	王玢, 中国纺织信息中心流行趋势部高级趋势研究员; FASHION INSIGHT 编辑 Bin Wang, Senior Trend Researcher of Trends Department, China Textile Information Center; Editor of FASHION INSIGHT	普通话 * Mandarin*
11:00 - 11:30 5.1-K148	<b>论坛 Forum</b> 山东联润: 紧柔纺® 专利技术解锁时尚与机能的无限融合 Shandong Long Run: Sirofil-Compact Spinning® - Unlock Infinite Integration of Fashion and Function	纺织新材料纱线流行趋势研究中心 朱培, 山东联润新材料科技有限公司, 总经理助理 Pei Zhu, Executive Assistant to the General Manager, Long Run Textile Co Ltd	普通话 * Mandarin*
11:30 - 12:00 5.1-K148	<b>论坛 Forum</b> 江苏丹毛 2027 春夏趋势面料分享 SS 2027 Trend Fabric Sharing - Danmao	女装精毛纺面料流行趋势研究中心 花香, 江苏丹毛纺织股份有限公司, 针织产品开发经理 Fabrics China Trend Research Center - Worsted Textiles for Womenswear Hua Xiang, Knitted Product Development Manager, Jiangsu Danmao Textile Co Ltd	普通话 * Mandarin*
12:00 - 12:30 5.1-K148	<b>论坛 Forum</b> 鲁泰集团 2027 春夏新品趋势 Luthai Group's 2027 Spring & Summer New Product Trends	色织面料流行趋势研究中心 孙艳柳, 鲁泰纺织股份有限公司, 设计师 Fabrics China Trend Research Center - Yarn dyed Textiles Yanliu Sun, Designer, Luthai Textile	普通话 * Mandarin*
12:30 - 13:00 5.1-K148	<b>论坛 Forum</b> 精工深耕·价值共生——纬一的产品矩阵和创新实践 Precision Craftsmanship & Deep Cultivation · Value Symbiosis - Weiyi's Product Matrix and Innovative Practices	人造皮革流行趋势研究中心 胡梦婷, 宁波纬一长毛绒有限公司, 趋势中心 Fabrics China Trend Research Center - Artificial Fur Mengting Hu, Trend Center, Ningbo Weiyi Plush Co Ltd	普通话 * Mandarin*
16:25 - 16:55 6.1-A143	<b>研讨会 Seminar</b> 焕彩新生·质启未来 Revitalizing with New Vibrance - Quality Initiates the Future	李杰, 华孚时尚股份有限公司, 市场部副总监 Jie Li, Deputy Director of Marketing Department, Huafu Fashion Co Ltd	普通话 Mandarin

\* 提供普通话 ↔ 英语同声传译

\*\* 提供日语 ↔ 普通话 & 英语翻译

\* Mandarin ↔ English Simultaneous Interpretation will be provided

\*\* Japanese ↔ Mandarin & English Interpretation will be provided

# 活动总览 – 可持续发展议题

## EVENT SCHEDULE – ECONOGY TALKS

地点 Venue  
5.1-K48  
可持续发展论坛  
Econogy Talks



### 2026.3.11

时间 Time 地点 Venue	主题 Topic	讲者 Speakers	语言 Language
10:35 - 11:05 5.1-K48	<b>研讨会 Seminar</b> 当可持续遇见时尚：GOTS 标签—— 纺织品可持续与公平的保障 Where Sustainability Meets Style: The GOTS Label - Assurance of Sustainability and Fairness in Textiles	时怡, Global Standard gGmbH, 亚太区代表人 Felicia Shi, Representative in APAC, Global Standard gGmbH	普通话 * Mandarin*
11:10 - 11:40 5.1-K48	<b>研讨会 Seminar</b> TE+GOTS 标准更新: MMS + GOTS 8.0 要点解析 TE+GOTS Standard Updates: Analysis of MMS & GOTS 8.0 Core Highlights	张韬, 世优认证 (上海) 有限公司, 技术部经理 Tao Zhang, Technical Manager, Control Union Certification (Shanghai) Co Ltd	普通话 * Mandarin*
11:45 - 12:15 5.1-K48	<b>研讨会 Seminar</b> 可持续视角下的全球供应链追溯实践 与能力建设 Sustainable Practice & Capability for Global Supply Chain Traceability	谢璧容, 客户与供应链业务经理, TextileGenesis (简称 TG 公司, 为 Lectra 旗下企业) Charlene Xie, Customer Engagement & Service Manager, TextileGenesis, a Lectra company	普通话 * Mandarin*
12:20 - 12:50 5.1-K48	<b>研讨会 Seminar</b> 2026 年 OEKO-TEX® 新规解析及 PFAS 监管重点 Analysis of the 2026 OEKO-TEX® New Regulations and Key Focus Areas in PFAS Oversight	聂辰, 海恩斯坦检测认证 (上海) 有限公司, 业务总监 Charles Nie, Business Director, Hohenstein Laboratories (Shanghai) Co Ltd	普通话 * Mandarin*
13:05 - 15:05 5.1-K48	<b>论坛 Forum</b> 共担·共治·共赢: 纺织服装行业 “责任链动”计划启动仪式 Responsibility-Participation- Prosperity: Launch Event of the "Responsible Chain in Motion" Initiative for Textile and Apparel Industry	第一部分: 开幕致辞 第二部分: 主题演讲 第三部分: 合作伙伴代表主旨发言 第四部分: 会议总结 Part 1: Opening Speech Part 2: Keynote Speech Part 3: Keynote Speeches by Partnership Representatives Part 4: Closing Remarks	普通话 * Mandarin*

### 2026.3.12

时间 Time 地点 Venue	主题 Topic	讲者 Speakers	语言 Language
10:20 - 11:50 5.1-K48	<b>论坛 Forum</b> 时尚新定义: 废料就是新资源 Redefining Fashion: Waste Is the New Resource	主持人 Moderator Nissa Cornish, Redress, 执行总监 Nissa Cornish, Executive Director, Redress  对话嘉宾 Panelists Carla Zhang, Le Ngok, 创始人及创意总监及 2025 年度 “Redress 设计大赛” 大奖得主 Eva Engelen, Fashion for Good, 创新经理 田如茵, Sunday Square, 创始人及 2024 年度 “Redress 设计大赛” 优异奖得主 姚雅文博士, 超级皮儿, 研发总监 Carla Zhang, Founder & Creative Director, Le Ngok & Redress Award 2025 Winner Eva Engelen, Innovation Manager, Fashion for Good Ruyin Tian, Founder, Sunday Square & Redress Design Award 2024 Runner-up Dr. Yawen Yao, R&D Director, PEELSPHERE	英语 * English*

12:00 - 12:20 5.1-K48	<b>研讨会 Seminar</b> 经纬天下: 全球纺织市场的全景探索 与战略突围 Your Gateway to Global Textile Markets	Olaf Schmidt, 法兰克福展览集团纺织品与纺织技术, 副总裁 Olaf Schmidt, Vice President Textiles and Textile Technologies, Messe Frankfurt Exhibition GmbH	英语 * English*
12:20 - 12:25 5.1-K48	<b>研讨会 Seminar</b> Econogy Tour 巡馆导览 预热说明会 Econogy Tour Preview Session	Karl Borgschulze, 咨询服务国际董事总经理 Karl Borgschulze, Managing Director, Consulting Service International	英语 * English*
12:30 - 13:00 5.1-K48	<b>研讨会 Seminar</b> 从更高的时空维度看可持续发展 Sustainable Development in Higher Dimensions	邱德军, 上海瑞札新材料有限公司, 总经理 Johnson Qiu, General Manager, Shanghai Ruizha New Materials Co Ltd	普通话 * Mandarin*
13:25 - 14:55 5.1-K48	<b>研讨会 Seminar</b> TESTEX 180 <sup>th</sup> Anniversary Special Event TESTEX 特思达 180 周年庆活动	TESTEX 特思达	普通话 * Mandarin*
15:10 - 15:40 5.1-K48	<b>研讨会 Seminar</b> PFAS 全球管控趋势及循环经济合规 解决方案 Global Trends in PFAS Regulation and Compliance Solutions for Circular Economy	贺世忠, SGS 通标标准技术服务有限公司, 资深项目经理 Adam Gardiner, 可持续纺织促进会, 再生项目总监 Seeker He, Senior Project Manager, SGS-CSTC Standards Technical Services Co Ltd Adam Gardiner, Recycled Lead, Textile Exchange	普通话 * Mandarin* 英语 * English*
15:50 - 16:20 5.1-K48	<b>研讨会 Seminar</b> 从愿景到合规: 欧盟绿色协议如何重 塑纺织业的生产者责任 From Vision to Compliance: How the European Green Deal is Reshaping Producer Responsibilities in the Textile Industry	贾彦, 北京爱科赛尔认证中心有限公司, 生态产品事业部总经理 Yan Jia, General Manager of the Eco-products Division, Ecocert China	普通话 * Mandarin*
16:20 - 16:50 5.1-K48	<b>研讨会 Seminar</b> 海外市场纺织消费品监管动态解读 Review of Regulatory Updates for Textile Consumer Goods in Overseas Markets	王璐璐, 天祥集团, 纺织及鞋事业部高级技术支持 仇彬鸿, 天祥集团, 绿色环境部副总经理 Lorraine Wang, Softlines - Senior Technical Support, Intertek Joyce Qiu, Green Initiatives Department - Asst. General Manager, Intertek	普通话 * Mandarin*

\* 提供普通话 ↔ 英语同声传译

\* Mandarin ↔ English Simultaneous Interpretation will be provided

# 活动总览 – 市场信息及营销策略

## EVENT SCHEDULE – MARKET INFORMATION & BUSINESS STRATEGIES



### 2026.3.11

时间 Time 地点 Venue	主题 Topic	讲者 Speakers	语言 Language
11:50 - 12:20 6.1-A143	<b>研讨会 Seminar</b> 认证助力纺织企业可持续发展和产品创新 Certification Supports Sustainable Development and Product Innovation in Textile Enterprises	文正宇, 中联品检 (北京) 技术集团有限公司, 绿色低碳业务负责人 Zhengyu Wen, Director of Green and Low-Carbon Business, United Testing Services (Beijing) Technology Group Co Ltd	普通话 Mandarin
13:00 - 14:00 6.1-A143	<b>论坛 Forum</b> 2026 徐州 (上海) 高端纺织产业投资推介会 2026 Xuzhou (Shanghai) High-End Textile Industry Investment Promotion Conference	第一部分: 领导致辞及推介 徐州市政府领导致辞并推介 中国纺织工业联合会领导致辞 第二部分: 专题推介 沛县专题推介 睢宁县专题推介 新沂市专题推介 第三部分: 企业代表发言 在徐投资高端纺织重点企业代表发言 第四部分: 合作项目展示 Part 1: Leadership Speech & Presentation Speech and Presentation by the Leader of Xuzhou Municipal Government Speech by China National Textile and Apparel Council (CNTAC) Leadership Part 2: Special Presentation Peixian County Special Presentation Suining County Special Presentation Xinyi City Special Presentation Part 3: Remarks by Enterprise Representative Remarks from Key High-End Textile Enterprise with Operations in Xuzhou Part 4: Cooperative Project Showcase	普通话 Mandarin

### 2026.3.12

时间 Time 地点 Venue	主题 Topic	讲者 Speakers	语言 Language
13:15 - 14:15 5.1-K148	<b>论坛 Forum</b> 毛孩时尚: 探索宠物服装的创新与趋势 Beyond the Collar: Trends and Innovations in Pet Apparel	刘婉婷, 毕马威中国, 零售及消费品行业合伙; 2025 中国宠物行业市场报告组委会主席 王艳民, 功能性产品市场拓展经理, 兰精集团 Sherry Liu, Partner of Consumer & Retail, Partner-in-charge of 2025 Pet Industry Report, KPMG China Fred Wang, BD Manager, Functional Wear, Lenzing Group	普通话 * Mandarin*
14:50 - 15:20 5.1-K148	<b>研讨会 Seminar</b> Naia™ Lyte: 伊士曼醋酸纤维带来全新轻薄突破 Eastman Naia™ Lyte brings a Brand-New Breakthrough in Lightweight Textile Solutions	柯夏梦, 伊士曼 (中国) 投资管理有限公司, 商务开发经理 Karina Ke, Business Development Manager, Eastman Chemical Company	普通话 * Mandarin*

\* 提供普通话 ↔ 英语同声传译  
\* Mandarin ↔ English Simultaneous Interpretation will be provided

# 活动总览 – 技术

## EVENT SCHEDULE – TECHNOLOGY AND SOLUTIONS

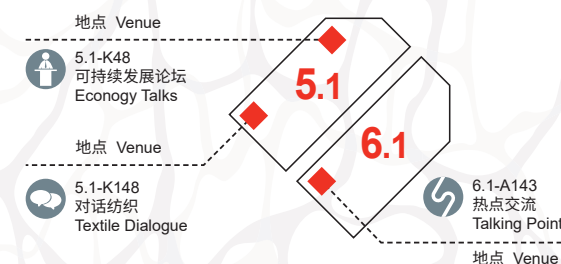

### 2026.3.11

时间 Time 地点 Venue	主题 Topic	讲者 Speakers	语言 Language
10:40 - 11:10 6.1-A143	<b>研讨会 Seminar</b> 双碳时代下的材料破局: 海藻基生物材料的功能化创新与应用 Breakthrough of Materials in the Era of Dual Carbon: Functional Innovation and Application of Algae-based Biomaterials	刘春梅, 山东海纤生物材料科技有限公司, 总经理 Chunmei Liu, General Manager, Shandong Healcell Biomaterial Technology Co Ltd	普通话 Mandarin
11:15 - 11:45 6.1-A143	<b>研讨会 Seminar</b> 生物基热塑性薄膜实践指引: 源自自然, 成就性能 A Practical Guide to Bio-based Thermoplastic Film: From Nature to Performance	李学庆博士, 浙江环龙新材料科技有限公司, 技术总监 Dr Xueqing Li, Technical Director, Zhejiang Huanglong New Material Science & Technology Co Ltd	普通话 Mandarin
14:20 - 16:20 6.1-A143	<b>论坛 Forum</b> 下一站新增长: 面料产品开发的创新突破与场景引领 Next Stop: New Growth   Innovative Breakthroughs and Application-Driven Fabric Product Development	缪恬, 福建永荣锦江股份有限公司, 品牌经理 蒋璐, 凯喜雅智纺科技有限公司, 总经理 涂强, 广州市谊兴纺织有限公司, 品牌营销总监 刘阳, 东莞德永佳纺织制衣有限公司, 推广部负责人 王莹, 广州帛璟纺织品有限公司, 总经理 赵丽萍, 浙江富润纺织有限公司, 开发部部长 Tian Miao, Brand Manager of Brand and Commercial Department, Fujian Yongrong Jinjiang Co Ltd Lu Jiang, General Manager, Zhejiang Cathaya Intelligent Textile Technology Co Ltd Qiang Tu, Brand Marketing Director, Guangzhou Winwin Textile Co Ltd Yang Liu, Promotion Department Director, Dongguan Texwinca Textile & Garment Limited Kun Wang, General Manager, Guangzhou Bojing Textile Co Ltd Liping Zhao, Director of Development Department, Zhejiang Furun Textile Co Ltd	普通话 Mandarin
15:15 - 15:45 5.1-K48	<b>研讨会 Seminar</b> 塑造自然本真的美感: 天丝™ 莱赛尔 -HV100 纤维 Crafting Natural Imperfections TENCEL™ Lyocell-HV100: Our New Solution Mirroring Nature's Irregularities	任雯洁, 兰精集团, 中国区业务拓展经理 Vivian Ren, Business Development Manager, Lenzing Group	普通话 * Mandarin*
15:55 - 16:25 5.1-K48	<b>研讨会 Seminar</b> 源于自然, 赋能性能: 再生涤纶与仿麻技术创新 Where Nature Inspires Performance: Circular Polyester and Linen-Like Innovation	袁露嘉, 苏州优富纺织品有限公司, 销售及市场副总裁 Luka Yuan, VP Sales & Marketing, Unifi Textiles (Suzhou) Co Ltd	普通话 * Mandarin*
16:25 - 16:55 6.1-A143	<b>研讨会 Seminar</b> 一直皱, 烫不平——更松弛的「盐缩」肌理皱 Constantly Wrinkled, Impossible to Iron Flat — The More Relaxed "Salt-Shrink" Textured Silk	李鹏, 浙江凯喜雅国际股份有限公司, 国家级工业设计中心主任 Peng Li, Director of National Industrial Design Center, Zhejiang Cathaya International Co Ltd	普通话 Mandarin
16:35 - 17:05 5.1-K48	<b>研讨会 Seminar</b> 与染色醋酸纱线相比, 原液染色醋酸纱线的优势 Advantages of Dope-Dyed Acetate Yarn Compared to Dyed Acetate Yarn	Martynas Ugianskis, DP Acetate, 总经理 Martynas Ugianskis, Director, DP Acetate	普通话 * Mandarin*

# 活动总览 – 技术

## EVENT SCHEDULE – TECHNOLOGY AND SOLUTIONS

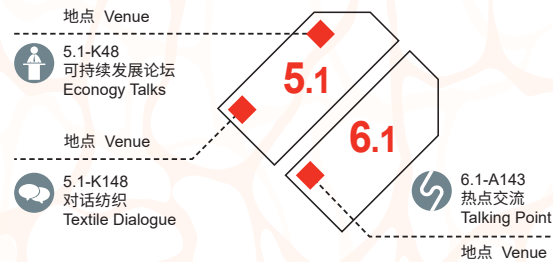

### 2026.3.12

时间 Time 地点 Venue	主题 Topic	讲者 Speakers	语言 Language
10:40 - 12:40 6.1-A143	<b>论坛 Forum</b> 智链时尚：纺织行业数字化转型路径构建与实践应对 Smart Chain Fashion: Path Construction and Practical Responses to Digital Transformation in the Textile Industry	阙右根, 美泰克斯 (苏州) 科技有限公司, 总经理 殷珉, 杭州环峪数智科技有限公司, 供应链总监 吕慧明, 南通巨联数字科技有限公司, 机器视觉产品高级经理 许展瑜, 中国纺织信息中心, 时尚智能部项目经理 Yougen Que, General Manager, My Tex (Suzhou) Technology Co Ltd Min Yin, Supply Chain Director, ValleyDelta (HuanYu Technology) Huiming lv, Senior Manager of Machine VisionProducts, Nantong Julian Digital Technology Co Ltd Zhanyu Xu, Project Manager, Fashion Intelligence Dept., China Textile Information Center	普通话 Mandarin
12:50 - 13:20 6.1-A143	<b>研讨会 Seminar</b> 福华世家 × 沃太能源——领航数字化工厂的绿色变革之路 Fuhua Weaving × Alpha ESS – Pioneering the Green Transformation Path of Digitalized Factories	洪星, 沃太能源股份有限公司, 综合能源 CTO Xing Hong, CTO of Integrated Energy Department, Alpha ESS Co Ltd	普通话 Mandarin
13:30 - 15:40 6.1-A143	<b>论坛 Forum</b> COLORO TALK: 时尚产业全链路色彩创新 COLORO TALK: Color Innovation Across the Fashion Industry Ecosystem	王刘莹, COLORO, 色彩项目总监 米曦, COLORO, 副总经理 彭无恙, Datacolor, 大区客户经理 Liuying Wang, Color Project Director, COLORO Mi Xi, Deputy Managing Director, COLORO Blake Peng, Key Account Manager, Datacolor	普通话* Mandarin*
15:30 - 17:30 5.1-K148	<b>论坛 Forum</b> “数智纺织 绿色共生” 2026 国际纺织产业数字化应用趋势论坛 Digital & Intelligent Textiles, Green Symbiosis 2026 International Textile Industry Digital Application Trend Forum	胡柯华, 中国纺织工业联合会社会责任办公室副主任 喻波, 深圳市智能制造产业促进会联席会长 陈德宏, TextileGenesis (简称 TG 公司, 为 Lectra 旗下企业), 东亚区总监 罗玉成, 绍兴市柯桥织造印染产业大脑运营有限公司, 副总经理 Kehua Hu, Deputy Director of the Social Responsibility Office, China National Textile and Apparel Council (CNTAC) Bo Yu, Co-Chairman of Shenzhen Association for the Promotion of Intelligent Manufacturing Industry Simon Chen, Regional Director, East Asia, TextileGenesis, a Lectra company Yucheng Luo, Deputy General Manager of Shaoxing Keqiao Weaving, Printing and Dyeing Industry Brain Operation Co Ltd	普通话* Mandarin*
15:50 - 16:20 6.1-A143	<b>研讨会 Seminar</b> 内外之间, 众行之履: 2026 户外探索面料解决策略 Interface by Design: 2026 Technical Textiles for Collective Adventures	闻庆, 昆山东利新材料科技有限公司, 产品总监 Mincor, Director of Product, Kunshan Doonly New Materials Technology Co Ltd	普通话 Mandarin

\* 提供普通话 ↔ 英语同声传译

\* Mandarin Chinese ↔ English Simultaneous Interpretation will be provided

# 功能性产品区 – 产品发布会

## FUNCTIONAL LAB – PRODUCT PRESENTATIONS



### 2026.3.11

时间 Time 地点 Venue	主题 Topic	讲者 Speakers	语言 Language
10:40 - 11:00	循环赋能·智创新生——UNIFI 明星产品全链路可持续解决方案解析 Circular Empowerment • Smart Innovation	袁露嘉, 苏州优富纺织品有限公司, 销售及市场副总裁 Luka Yuan, VP Sales & Marketing, Unifi Textiles (Suzhou) Co Ltd	普通话 Mandarin
11:15 - 11:35	针织人造丝在时装方面的功能性应用 Functional Applications of Knitted Rayon in Fashion	孙小杰, 绍兴福丝纺织品有限公司, 总经理 David Sun, General Manager, Shaoxing Fus Textile Co Ltd	普通话 Mandarin
11:50 - 12:10	环保再生材料应用 Eco-friendly Recycled Materials Application	陈家平, 香港华阳国际控股有限公司, 研发总监 Jiaping Chen, Director of Research and Development, Sunshinetex International Holdings (HK) Limited	普通话 Mandarin
13:00 - 13:20	lavalan® 羊毛保温材料 lavalan® The Wool Insulation	邱德军, 上海瑞札新材料有限公司, 总经理 Johnson Qiu, CEO, Shanghai Ruizha New Materials Co Ltd	普通话 Mandarin
13:40 - 14:00	从自然原点到可持续时尚——探索天丝羊毛的舒适美学 From Natural Origins to Sustainable Fashion – The Art of Comfort in TENCEL™ & Wool Blends	樊家恺, 睿程智造 (香港) 科技有限公司 Kyle Fan, Regen-Tech Fashion (HongKong) Co Limited	普通话 Mandarin
14:20 - 14:40	如何解决锦氨混纺面料普遍存在的疲劳缺陷 How to Solved the Fatigue Disadvantages Commonly Found in Traditional Nylon-spandex Fabrics Without Adding Spandex	熊紫灿, 上海吉帛纺织品有限公司 Gavin, Shanghai Jibo Textile Co Ltd	普通话 Mandarin
15:00 - 15:20	绿色纺织: PFAS 管控和可重复使用的生理裤 Green Textiles: PFAS Regulatory Requirements and Reusable Period Underwear	林凤玲, 海恩斯坦检测认证 (上海) 有限公司, 实验室技术经理 Lisa Lin, Technical Supervisor, Hohenstein Laboratories (Shanghai) Co Ltd	普通话 Mandarin
15:40 - 16:00	舒适经济新风口: 棉莫空气层解锁家居服与卫衣新赛道 Comfort Economy's New Frontier: Cotton-modal Air Layer Paves New Paths for Loungewear and Hoodie Innovation	赵伟维, 常州市恒纶纺织有限公司, 业务经理 Alice Zhao, Business Manager, Changzhou Henglun Textile Co Ltd	普通话 Mandarin

# 功能性产品区 – 产品发布会

## FUNCTIONAL LAB – PRODUCT PRESENTATIONS

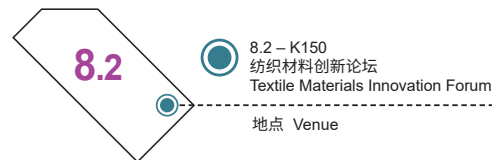

### 2026.3.12

时间 Time 地点 Venue	主题 Topic	讲者 Speakers	语言 Language
10:40 - 11:00	舒适经济新风口：棉莫空气层解锁家居服与卫衣新赛道 Comfort Economy's New Frontier: Cotton-modal Air Layer Paves New Paths for Loungewear and Hoodie Innovation	赵伟维，常州市恒纶纺织有限公司，业务经理 Alice Zhao, Business Manager, Changzhou Henglun Textile Co Ltd	普通话 Mandarin
11:15 - 11:35	绿色纺织：PFAS 管控和可重复使用的生理裤 Green Textiles: PFAS Regulatory Requirements and Reusable Period Underwear	林凤玲，海恩斯坦检测认证（上海）有限公司，实验室技术经理 Lisa Lin, Technical Supervisor, Hohenstein Laboratories (Shanghai) Co Ltd	普通话 Mandarin
11:50 - 12:10	如何解决锦氨混纺面料普遍存在的疲劳缺陷 How to Solved the Fatigue Disadvantages Commonly Found in Traditional Nylon-spandex Fabrics Without Adding Spandex	熊紫灿，上海吉帛纺织品有限公司 Gavin, Shanghai Jibo Textile Co Ltd	普通话 Mandarin
13:40 - 14:00	环保再生材料应用 Eco-friendly Recycled Materials Application	陈家平，香港华阳国际控股有限公司，研发总监 Jiaping Chen, Director of Research and Development, Sunshinetex International Holdings (HK) Limited	普通话 Mandarin
14:20 - 14:40	针织人造丝在时装方面的功能性应用 Functional Applications of Knitted Rayon in Fashion	孙小杰，绍兴福丝纺织品有限公司，总经理 David Sun, General Manager, Shaoxing Fus Textile Co Ltd	普通话 Mandarin
15:00 - 15:20	循环赋能·智创新生——UNIFI 明星产品全链路可持续解决方案解析 Circular Empowerment · Smart Innovation	袁露嘉，苏州优富纺织品有限公司，销售及市场副总裁 Luka Yuan, VP Sales & Marketing, Unifi Textiles (Suzhou) Co Ltd	普通话 Mandarin
15:40 - 16:00	从自然原点到可持续时尚——探索天丝羊毛的舒适美学 From Natural Origins to Sustainable Fashion - The Art of Comfort in TENCEL™ & Wool Blends	樊家恺，睿程智造（香港）科技有限公司 Kyle Fan, Regen-Tech Fashion (HongKong) Co Limited	普通话 Mandarin
16:20 - 16:40	lavalan® 羊毛保温材料 lavalan® The Wool Insulation	邱德军，上海瑞札新材料有限公司，总经理 Johnson Qiu, CEO, Shanghai Ruizha New Materials Co Ltd	普通话 Mandarin

### 2026.3.12

#### 发布会 Launch

时间 Time	活动主题 Content	发布单位 Company
10:20 - 11:00 8.2-K150	循环·蜕变·启新——佳人 T2T 循环解决方案创新发布会 Circle · Transform · Launch - Jia Ren T2T Recycling Solution Innovation Launch Conference	浙江佳人新材料有限公司 Zhejiang Jiaren New Materials Co Ltd
11:20 - 12:00 8.2-K150	“优品纤选”——打造国产高品质莱赛尔产业链 Upper Fiber: Pioneering Domestic the High-Quality Lyocell Industry Chain	中国化学纤维工业协会 China Chemical Fibers Association 中国棉纺织行业协会 China Cotton Textile Association
12:20 - 13:00 8.2-K150	榛丝·启新境——榛丝高性能纤维新品发布会 Acrysilk · A New Realm-Acrysilk High-Performance Recycled Fiber Launch	中国石油天然气股份有限公司大庆石化分公司 Daqing Petrochemical Company, Petrochina
13:20 - 14:00 8.2-K150	天赋自然力·质启新性能—— FURIX™ 生物基高性能 PEF 纤维创新应用发布会 FURIX™ Global Launch: Born from Nature Built for Performance Unlocking Nature's Potential in High-Performance PEF Fibers	中科国生（杭州）科技有限公司 GS Biomats Co Ltd
14:20 - 15:00 8.2-K150	绒·界新生——海科多功能“云绒”填充纤维新品发布会 New Realm, New Fiber - Oceantex Multifunctional "Cloud-Fiber" New Product Launch	江苏海科纤维有限公司 Jiangsu Oceantex Fiber Co Ltd
15:15 - 16:00 8.2-K150	纤启新程 深绿共赢—— 新乡白鹫创新产品应用发布会暨高质量发展论坛 Weaving a New Journey, Achieving Deep Green and Win-win Results - Xinxiang Bailu Innovative Product Application Launch and High-Quality Development Forum	新乡化纤股份有限公司 Xinxiang Chemical Fiber Co Ltd

#### 桐昆·中国纤维流行趋势入选纤维专场 Tongkun · China Fibers Fashion Trends Deep Interpretation Forum

时间 Time	活动主题 Content	公司 / 演讲人 Company / Speaker
16:00 - 16:15 8.2-K150	桐昆·精研加弹芯动力 勇拓高端纤维新赛道 Tongkun · Delveinto Texturing to Forge Innovation Power, Venture Boldly into the New Track of High-end Fibers	沈红仙，桐昆集团股份有限公司 Ms Shen Hongxian, Tongkun Group Co Ltd
16:15 - 16:30 8.2-K150	会呼吸的尼龙——伊纶® 用植物基科技重塑可持续穿着新体验 Breathable Nylon - EYLON® Uses Plant-based Technology to Redefine the Sustainable Wearing Experience	郑文昌，黑龙江伊品新材料有限公司 Mr Zheng Wenchang, Heilongjiang Eppen New Materials Co Ltd
16:30 - 16:45 8.2-K150	SUNHOT——高效的吸光发热保暖纤维 SUNHOT - High-efficiency Light-absorbing, Heat-generating, and Warmth-retaining Fiber	王荣华，太极石（上海）科技有限公司 Mr Wang Ronghua, TAI CHI Stone (Shanghai) Technology Co Ltd
16:45 - 17:00 8.2-K150	新纤维新动能，织就未来蓝图 New Fibers, New Momentum, Weaving the Blueprint for the Future	徐慧燕，浙江金旗新材料科技有限公司 Ms Xu Huiyan, Zhejiang Jinqi New Material Tech Co Ltd
17:00 - 17:15 8.2-K150	聚乳酸 / 聚酰胺皮芯复合纤维的开发 Development of Polylactic Acid/Polyamide Core-sheath Composite Fibers	李顺希，凯泰特种纤维科技有限公司 Mr Li Shunxi, CTA High-tech Fibre Co Ltd
17:15 - 17:30 8.2-K150	高值高品质纺织用竹原纤维制备及其综合应用 Preparation of High-value, High-quality Bamboo-based Textile Fibers and Their Comprehensive Applications	王乐军，浙江青士新材料科技有限公司 Mr Wang Lejun, Zhejiang Bamboo New Material Technology Co Ltd

### 2026.3.13

#### 绿色低碳发展专场 Green & Low-carbon Development Forum

时间 Time	活动主题 Content	公司 / 演讲人 Company / Speaker
10:15 - 10:30 8.2-K150	循环为始，共赴纤维进化之路 Cycle as the Beginning, Embarking on the Journey of Fiber Evolution Together	刘辉，唐山三友集团兴达化纤有限公司 Mr Liu Hui, Tangshan Sanyou Group Xingda Chemical Fibre Co Ltd
10:30 - 10:45 8.2-K150	多彩纤维赋能品质生活 Colorful Fibers Empower Quality Living	党妍姝，中国石油大庆石化分公司化纤部 Ms Dang Yanshu, The Fiber Department of Petrochina Daqing Petrochemical Company
10:45 - 11:00 8.2-K150	新登利环保·T2T 化学法再生 BHET 工艺的市场应用 Syzerly Eco- Market Applications of T2T Chemical Recycling BHET Process	刘宁，安徽新登利环保科技有限公司 Mr Liu Ning, Anhui Syzerly Environmental Protection Technology Co Ltd
11:00 - 11:15 8.2-K150	高温微交联陶瓷化赋能本质阻燃不熔滴尼龙 66 纤维 Non Dripping FR Nylon 6,6 Fibers and its Application	付常俊，上海安凸阻燃纤维有限公司 Mr Fu Changjun, Shanghai ANTU FR Fibers Co Ltd
11:15 - 11:30 8.2-K150	非粮路线生产聚乳酸，助力纤维行业绿色发展 Producing Polylactic Acid through NonGrain Routes to Promote Green Development of the Fiber Industry	范亚庆，安徽丰原生物纤维股份有限公司 Mr Fan Yaqing, Anhui BBFA Biofiber Co Ltd

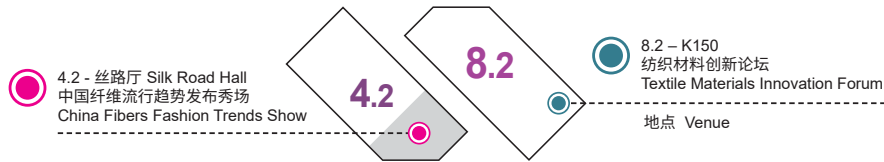

## 中国纤维流行趋势发布会及企业产品发布会 China Fibers Fashion Trends and Enterprise Product Launch

2026.3.11

时间 Time	活动主题 Content	发布单位 Company
10:30 - 11:45 4.2 丝路厅 Silk Road Hall	桐昆·中国纤维流行趋势 2026/2027 发布会 Tongkun • China Fibers Fashion Trends 2026/2027 Show	中国化学纤维工业协会 China Chemical Fibers Association 东华大学 Donghua University 中国棉纺织行业协会 China Cotton Textile Association 桐昆集团股份有限公司 Tongkun Group Co Ltd

## 纤维新视界——纺织材料创新论坛 New Fiber New World - Textile Materials Innovation Forum

2026.3.11

### 发布会 Launch

时间 Time	活动主题 Content	发布单位 Company
11:00 - 11:40 8.2-K150	智能调温·舒适随行—— Dynatex 丹特丝调温涤纶首发启动仪式 Intelligent Temperature Regulation, Comfort on the Go - Dynatex Thermoregulating Polyester Launch Ceremony	旭纶成纺织科技有限公司 Xuluncheng Textile Technology Co Ltd 伊隆旭纶科技有限公司 Elon Sunshine Technology Co Ltd
12:00 - 12:40 8.2-K150	九江经开区炼化一体化产业专场推介会 Jiujiang Economic and Technological Development Zone Refining and Chemical Integration Industry Promotion Conference	九江经济技术开发区管理委员会 Jiujiang Economic and Technological Development Zone Administrative Committee
13:00 - 13:50 8.2-K150	「敏」感肌密——华峰化学 x 安莉芳敏肌系列产品发布会 The Secret to Sensitive Comfort - Huafon x Embry Form Sensitive Skin Collection Launch	华峰化学股份有限公司 Huafon Chemical Co Ltd 安莉芳（中国）服装有限公司 Embry (China) Garments Ltd
14:05 - 14:50 8.2-K150	厚植天然，智拓新境——浙江青士竹原纤维产品发布会 Nurturing Nature, Pioneering Innovation - Zhejiang Qingshi Bamboo Fiber New Product Launch	浙江青士新材料科技有限公司 Zhejiang Bamboo New Material Technology Co Ltd
15:05 - 15:50 8.2-K150	酶解重构循环·旧衣焕启新生 ——德福伦生物酶解法 T2T 再生纤维联合发布会 From Textile to Textile, Powered by Enzymatic Renewal	上海德福伦新材料科技有限公司 Shanghai Different Advanced Material Co Ltd

### 桐昆·中国纤维流行趋势深度解读 Tongkun • China Fibers Fashion Trends Deep Interpretation Forum

时间 Time	活动主题 Content	公司 / 演讲人 Company / Speaker
16:00 - 16:40 8.2-K150	桐昆·中国纤维流行趋势 2026/2027 深度解读 Interpretation of Tongkun • China Fibers Fashion Trends 2026/2027	王华平，东华大学材料科学与工程学院 Mr Wang Huaping, College of Materials Science and Engineering, DHU
16:40 - 16:50 8.2-K150	纤暖桐行·益企共创——让企业公益更简单 Speech Topic: Fiber Warmth Walk • Co-creating for Good - Making Corporate Philanthropy Easier	陈梓豪，腾讯公益 Mr Chen Zihao, Tencent Charity
16:50 - 17:10 8.2-K150	纤语未来：从材料革新到场景应用的时代演进 Evolution from Material Innovation to Scenario-based Applications	邵新艳，北京服装学院运动时尚创新研究院 Ms Shao Xinyan, Sports Fashion Innovation Research Institute, Beijing Institute of Fashion Technology
17:10 - 17:30 8.2-K150	桐昆·中国纤维流行趋势 2026/2027 纤·迭代篇章入选纤维应用 趋势解析 Insights into 'Fiber • Evolution' Indicative Fiber Application Trends of Tongkun • China Fibers Fashion Trends 2026/2027	鲁成，东华大学服装与艺术设计学院 Ms Lu Cheng, College of Fashion and Design, DHU
17:30 - 17:45 8.2-K150	以纤维标准化工作为基，走品牌国际化之路 Base on Standardization, Embrace the Path of International Standards	孙燕琳，桐昆集团股份有限公司 Ms Sun Yanling, Tongkun Group Co Ltd

## 同期活动场地 Fringe Programme Venues

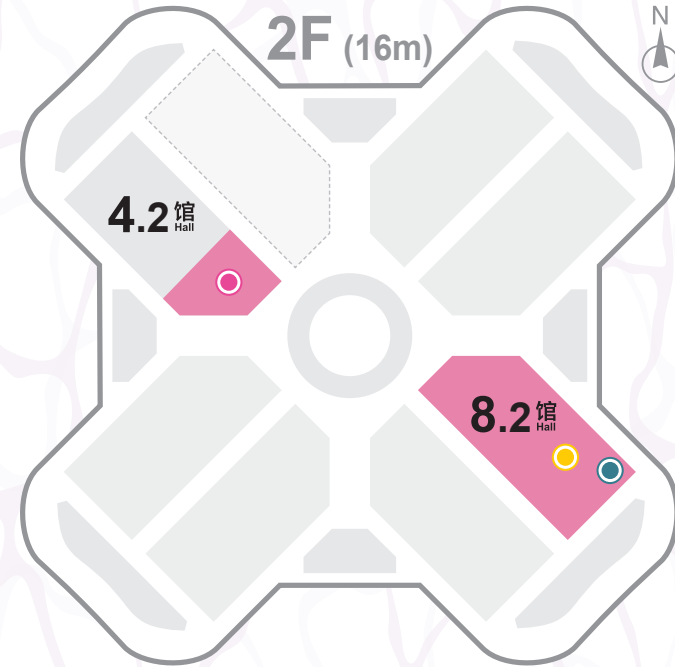

- 中国纤维流行趋势发布秀场  
(4.2馆 丝路厅)  
China Fibers Fashion Trends Show  
(Hall 4.2 - Silk Road Hall)
- 中国纤维流行趋势 /  
中国纱线流行趋势  
(8.2-G109)  
China Fibers Fashion Trends /  
China Yarns Fashion Trends  
(8.2-G109)
- 纺织材料创新论坛  
(8.2-K150)  
Textile Materials Innovation Forum  
(8.2-K150)

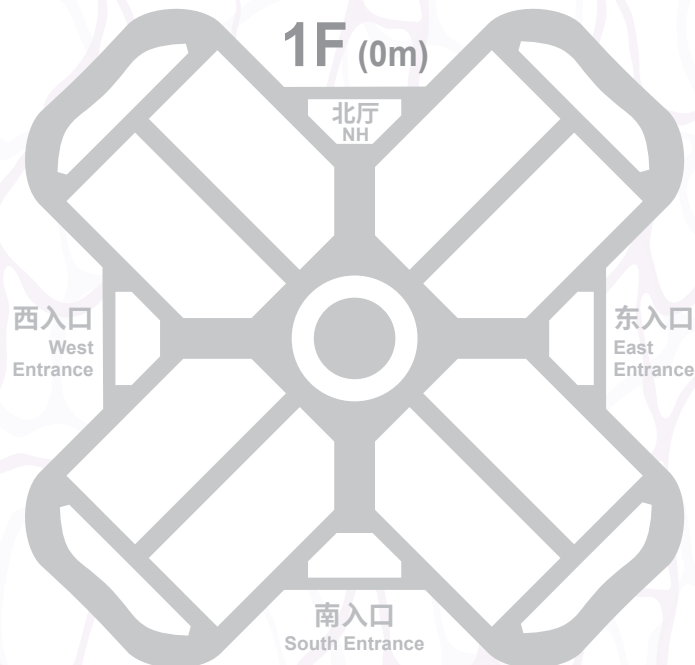



# yarnexpo

中国国际纺织纱线(春夏)展览会  
China International Trade Fair for Fibres and Yarns

2026.3.11 – 13

8.2<sup>馆</sup>  
Hall

国家会展中心 (上海)

Hall 8.2, National Exhibition and  
Convention Center (Shanghai), China

## 同期活动

Fringe Programme



研讨会日程  
Seminar schedule



messe frankfurt